

2-Port USB 3.0 8K DisplayPort KVM Switch

User's Manual



1. Introduction

The 2-Port USB 3.0 8K DisplayPort KVM Switch has a high quality and durability system to control two computers from one console of DP monitor, 2.1 surround sound audio, keyboard & mouse; shares with two USB 3.0 hubs.

This KVM switch was rigorously tested with the most popular OS including Windows®, Linux® and Mac computers. It features 8K video resolution and allows users to access two 8K-enabled computers from a single USB keyboard & mouse, and DisplayPort video console.

Feature

- Supports USB 3.0 hub and 2.1 surround sound audio
- Fully compliant with DisplayPort 1.4 HBR3, HDCP 2.3, HDR, DPCP; Supports DisplayPort Dual Mode (DP++) for direct output single-link DVI or HDMI signals via a powered DisplayPort-to-HDMI/DVI adaptor
- Supports UHD resolutions up to 7680 X 4320 @60Hz & 3840 X 2160 @144Hz 4:2:2 10bit; Supports 8K @60Hz (max. length: 2m in; 10m out ; 4K @144Hz (max. length: 2m in; 10m out)
- Supports Multi-Stream Transport (MST): displaying on multiple monitors/screen wall; Supports data rates up to 8.1 Gbps / lane or 32.4 Gbps total; Supports audio 32 Ch up to 1536 kHz sample rate
- Hosts selectable by Port selection pushbutton or hotkey
- Supports multimedia keyboards; wireless keyboards and mice; Mac/Sun keyboards etc.
- Console mouse port emulation/bypass feature supports most mouse drivers and multifunctional mice
- Compatible with widescreen LCD monitors
- Power on detection – either one of the computers is powered off, enables the KVM switch automatically switching to the other computer
- Supports 2.1 stereo audio out; Supports HD audio through DisplayPort playback.
- Provides USB 3.0 hub or audio out switching in independent method or combination with the host switching (USB HUB or audio Auto-Switch mode).
- Auto-Scan function (Time interval can be adjusted between 5~999 seconds when the Auto-Scan function is enabled)
- Firmware upgradable
- The USB 3.0 downstream ports comply with USB Battery Charging Spec 1.2; and enable to provide up to 1.5A (CDP mode) output current on each port
- Enables Port selection pushbutton switching computer by its LED color changing (Green/White)

Specification

Model No.	KVM-U3DP-V1	
Number Of Computer Controlled	2	
Selection Method	Port Selection Pushbutton / Hot Key	
LEDs	Host Selected LED (Amber) x 2	
	Port Selector LED (Green/White) x 1	
Compliant with USB Version	USB 1.1 / USB 2.0 / USB 3.0	
Compliant with HID Version	USB HID 1.11	
PC Connectors	Video	2 x DisplayPort 20-pin female
	USB	2 x USB 3.0 Type B female
	Speaker	2 x Audio Jack Female (Green)
Console port	Video	1 x DisplayPort 20-pin female
	Mouse	1 x USB Type A female
	Keyboard	1 x USB Type A female
	Speaker	1 x Audio Jack Female (Green)
	Selector	1 x Audio Jack Female (Black)

USB Downstream ports	2 x USB 3.0 Type A female	
Auto-Scan Interval	5~999 sec (default 20 sec)	
Operating system supported	Windows, Mac, Linux*	
Cable Length	USB 3.0	1.5m
	DP 1.4	
	Audio	
	Port Selector	1.8m
Connecting length based on 8K@60Hz	Input	≤2m
	Output	≤10m
Power mode	External power	
Power Supply	DC5V 4A	
Operating Temperature	0°C to 50°C	
Storage Temperature	-20°C to 60°C	
Humidity	0% - 80% RH (Non-condensing)	
Housing	Aluminum	
Dimensions (LxWxH)	170 x 74 x 30mm	

2. Package Contents

- 2-Port DisplayPort KVM Switch
- Port Selector
- 5VDC Power adapter
- 2 sets of DisplayPort / USB 3.0 / Audio Cables

3. Physical Diagram

Top view



Front view

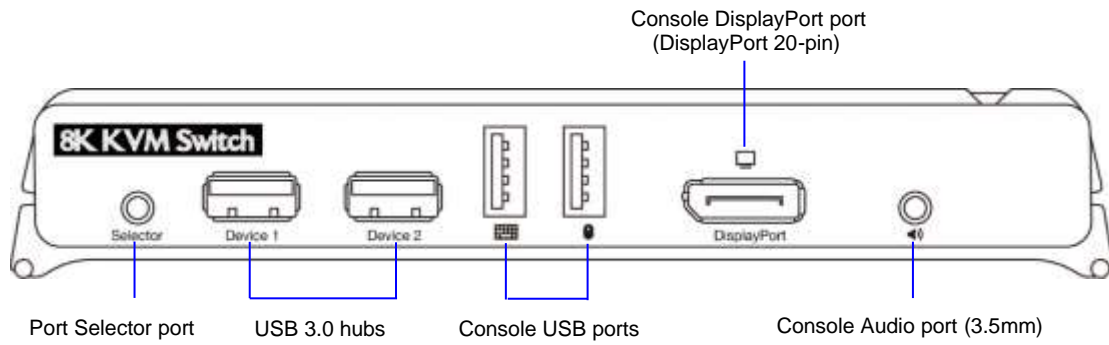

Rear view

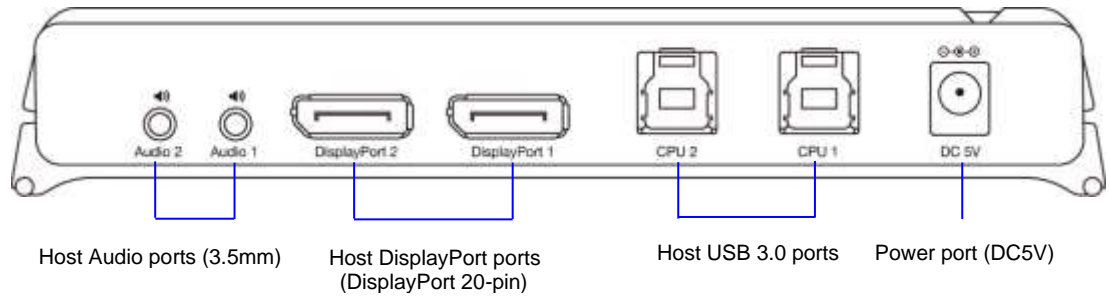

4. Connecting

Typical Application



5. Installation

5.1. System Requirements:

- 1 Computer: PC with 1 spare USB port and 1 DisplayPort port; if you wish to share speakers, computer must also have available audio ports.
- 2 Operating system: Windows 7, 8.1, 10, 11; Mac OSX, Linux or later.
- 3 DisplayPort cable to computer: DisplayPort male-to-male cable per computer.
- 4 USB 3.0 cable: USB 3.0 cable with Type-A end and Type-B end
- 5 Audio cable: 3.5mm speaker audio cable
- 6 One monitor supports DisplayPort interface
- 7 USB keyboard / mouse.
- 8 One speaker set with relative cable if necessary.
- 9 Other USB devices to USB downstream ports if necessary.
- 10 Port Selector

5.2. Hardware installation:

- 1 Connects USB keyboard / mouse and Port Selector to the console front ports of KVM.
- 2 Connects all audio cable to each computer, KVM, speakers if necessary.
- 3 Connects other USB devices / Smartphone to USB 3.0 Hub downstream ports if necessary.
- 4 Connects the monitor DisplayPort cable to the monitor output port of KVM.
- 5 Apply DC 5V power adaptor to power this KVM Switch.
- 6 Connects the DisplayPort cable between the DisplayPort port on the computer display card and the DisplayPort input port of KVM.
- 7 Make sure that the USB function of your computer is enabled and working properly. Connects the USB 3.0 cable Type-A end to the computer USB port, and the cable Type-B end to the KVM's USB upstream port.
- 8 Turn on the computers and make sure that the USB ports are enabled and working properly.

Note: The DisplayPort KVM switch is backward compatible with most DisplayPort 1.4 equipment running current graphics drivers, with the feature set being limited to that of your equipment (e.g. you may be limited to displaying in Clone / Mirror mode only). Compatibility with older graphics cards is not guaranteed.

Added Info

Port Selection pushbutton:

At the first installation, the default setting of button's LED is white (CPU 1). Press the button once indicates the unit switches to next port (CPU 2). The button's LED turns to green. And repeat pushing button indicates the unit switches to CPU 1. The button's LED turns to white.

If the Port Selector is connected to the KVM unit after the KVM unit been powered on or connected to host computers, it would beep once. In order to prevent errors, it would be fine to shut down all powers (incl. computers, speakers, monitor & KVM) before you plug in/out the Port Selector.

Description of Port Selector



5.3. USB enumeration time

This KVM Switch supports USB plug & play; all the components can be added and removed at any time without the need to shut the unit down. However, it will take several seconds to enumerate USB device, the time consumed depends on the number of USB devices and the speed of computer.

6. Operations

6.1. Port Selector's Operation

You can switch to any desired USB host connection with audio together by pushing the Port Selection pushbutton. You can also disable Audio Selection function by Hotkey. Please refer to section 6.4. Audio Selection Function.

6.2. Host Selection

Hotkey Support

The hotkey function is working on USB keyboard which is plugged at port marked with keyboard logo of the KVM. However, there is no hotkey support for the USB keyboard plugged to the USB 3.0 Hub downstream ports which locate on front panel of the KVM.

Specific Channel Selection

You can select the computer you want to control by the following hot keys:

- Press **[Ctrl] + [Ctrl] + Enter**: Switch channel (PC + USB 3.0 Hub + Audio) to next port
- Press **[Ctrl] + [Ctrl] + [D] + Enter**: Switch channel (PC only) to next port

Host Selected Indicator

The Host Selected LED (Amber) on KVM Top case indicates the host port status:

- **CPU 1**: Indicates the CPU 1 port is selected.
- **CPU 2**: Indicates the CPU 2 port is selected.

6.3. USB 3.0 Hub Selection

- Press **[Ctrl] + [Ctrl] + [Z] + Enter**, then switch USB 3.0 hubs to next port.

The USB 3.0 hub switching time is in one second after port switch, the reason to delay the USB 3.0 hub switch is to decrease USB enumeration loading if user changes active port very fast.

6.4. Audio Selection

- Press **[Ctrl] + [Ctrl] + [A] + Enter**, then switch Audio to next port.

6.5. Host USB Power on detect Function

- Press **[Ctrl] + [Ctrl] + [P] + [W] + [1]**, then Enables port switching by host USB Power on detect. (Default)
- Press **[Ctrl] + [Ctrl] + [P] + [W] + [0]**, then Disables host USB Power on detect.

6.6. Auto-Scan Function

Activate Auto-Scan

- Press **[Ctrl] + [Ctrl] + [S] + Enter** will activate Auto-Scan function, and the KVM will shift the display through the 2 ports sequentially.

Auto-Scan time Interval

The default time interval of Auto-Scan is 20 seconds. You can press **[Ctrl] + [Ctrl] + [S] + [n] + Enter** to adjust the time interval during auto-scan. The [n] can be 5 ~ 999.

Stop Auto-Scan

Press any other key on the keyboard: Press any keys on keyboard to turn off the Auto-Scan function; the buzzer beeps twice and the monitor screen will jump back to the original host port before auto-scan.

6.7. Buzzer Function

- Press **[Ctrl] + [Ctrl] + [B] + [1]**, then enables Buzzer function. (Default)
- Press **[Ctrl] + [Ctrl] + [B] + [0]**, then disables Buzzer function.

6.8. Hotkey Summary

Step 1		Step2	Action
Ctrl	Ctrl	Enter	Switch to next one host (PC + USB 3.0 hubs + Audio)
Ctrl	Ctrl	[A]+Enter	Switch Audio to next one host
Ctrl	Ctrl	[Z]+Enter	Switch USB 3.0 hubs to next one host
Ctrl	Ctrl	[D]+Enter	Switch to next one host (PC only)
Ctrl	Ctrl	[P]+[W]+[1]	Enable host USB power detect (Default)
Ctrl	Ctrl	[P]+[W]+[0]	Disable host USB power detect
Ctrl	Ctrl	[S]+Enter	Start to Auto-Scan
Ctrl	Ctrl	[S]+[n]+Enter	Auto-Scan time interval (Default: 20 sec) n=5~999 sec
Ctrl	Ctrl	[B]+[1]	Enable buzzer (Default)
Ctrl	Ctrl	[B]+[0]	Disable buzzer

Note:

- (1) The buzzer sound: (a) activate leading hotkey beeps once; (b) accomplish setting hotkey and Enter beeps once; (c) error hotkey beeps once and quit; (d) only press leading hotkey in a few seconds without further step beeps once and quit.
- (2) Any key to stop Auto-Scan, the buzzer beeps twice.

*The two-step hotkey sequence is used for quick function execution. The leading key is [Ctrl] + [Ctrl] by default. However, you may change the leading hotkey if you want.

By pressing **[Ctrl]** twice, **[H] + [A]** or **[B]**, then pressing **<Enter>**, you can change the leading hotkey.

The available leading hotkeys are shown below.

- **Set leading hotkey to mode [A] (For Mac keyboard only)**



- **Set leading hotkey to mode [B]**
[Ctrl] + [Ctrl]

Troubleshooting

If you are unable to get an acceptable image after following the installation instructions, try the troubleshooting tips below.

1. Is your equipment running the latest graphics driver? If not, download the latest graphics drivers for your equipment. Backward compatible with most DisplayPort 1.4 equipment running current graphics drivers, with the feature set being limited to that of your equipment (e.g. you may be limited to displaying in Clone / Mirror mode only). Compatibility with older graphics cards is not guaranteed.
2. Is the external power supply that came with the product connected and plugged into a working power source? For the product to function properly, it must be connected to and receiving power from the external power supply.
3. Were the power to the DisplayPort sources turned off prior to installation? If not, restart your computer/video sources.
4. What resolution are you trying to reach? The DisplayPort switch is tested to support video resolutions up to 7680 X 4320 @60Hz & 3840 X 2160 @144Hz 4:2:2 10bit. If you are not able to get an acceptable image, try lowering your computer's video resolution or adjusting the refresh rate.
5. What length cables are you using? The maximum cable lengths that can be used between the host computers and the DisplayPort KVM switch; and between the DisplayPort KVM switch and the monitor, are limited in the Installation section of this manual.
6. What type of cabling are you using? Inferior cabling can result in poor performance, so it is important that you use cables that can support the video resolution you are trying to obtain.
7. Test your cables to ensure they are working properly. For example, connect your DisplayPort cables between a source and monitor that you know works to see if the cable is functioning.

Regulatory Compliance

Disclaimer

Information in this document is subject to change without notice. The manufacturer does not make any representations or warranties (implied or otherwise) regarding the accuracy and completeness of this document and shall in no event be liable for any loss of profit or any other commercial damage, including but not limited to special, incidental, consequential, or other damages. No part of this document may be reproduced or transmitted in any form by any means, electronic or mechanical, including photocopying, recording or information recording and retrieval systems without the express written permission of the manufacturer. All brand names and product names used in this document are trademarks, or registered trademarks of their respective holders.

CE Certification

This equipment complies with the requirements relating to electromagnetic compatibility. It has been manufactured under the scope of RoHS compliance.

FCC Compliance Statement

This equipment generates and uses radio frequency and may cause interference to radio and television reception if not installed and used properly. This equipment has been tested and found to comply with the limits of a Class B digital device, pursuant to part 15 of the FCC Rules. These limits are designed to provide reasonable protection against harmful interference in a residential installation.

You are cautioned that changes or modification not expressly approved by the party responsible for compliance could void your authority to operate the equipment.

This device complies with part 15 of the FCC Rules. Operation is subject to the following two conditions:

- (1) This device may not cause harmful interference, and
- (2) This device must accept any interference received, including interference that may cause undesired operation



WEEE (Waste of Electrical and Electronic Equipment), Recycling of Electronic Products

In 2006 the European Union introduced regulations (WEEE) for the collection and recycling of all waste electrical and electronic equipment. It is no longer allowable to simply throw away electrical and electronic equipment. Instead, these products must enter the recycling process.

Each individual EU member state has implemented the WEEE regulations into national law in slightly different ways. Please follow your national law when you want to dispose of any electrical or electronic products. More details can be obtained from your national WEEE recycling agency.