

USB 3.2 Gen1 PD (Power Delivery) Charging Hub

User's Manual

USB3-C10PD / USB3-C20PD



USB3-C10PD



USB3-C20PD

Safety Instructions

- ※ Do not open the product. There are no user serviceable parts inside.
- ※ Qualified servicing personnel must only carry out any repairs or maintenance.
- ※ Never use damaged cables.
- ※ Do not expose the product to water or places of moisture.
- ※ This product is intended for indoor use only.
- ※ Do not place the product near direct heat sources. Always place it in a well-ventilated place.
- ※ Do not place heavy items on the product or the cables.

Introduction

The USB 3.2 Gen1 PD Charging Hub is a solution for quick charging or sync up to 10 and 20 USB 3.2 Gen1 devices. This is a perfect tool to effectively save energy and cool down the unit's heat. Also is ideal for large capacity USB station in-house that enables charging and syncing at a time; automatically recharging once the devices connected have consumed their power with remaining 90% (approximately) after fully charged. Places such as classroom in school, businesses conference or meeting in organizations.

Features

- Supports iOS, iPadOS, Android devices and MacBook Air, MacBook Pro or Chromebook etc.
- Supports USB PD 3.1 (PPS) / USB Battery Charging Spec 1.2 at Sync & Charge mode.
- Enables to deliver output current of each port up to 27W; supports 5V 3A / 9V 3A / 12V 2.25A / 15V 1.8A either at Sync mode or Charge mode on each port.
- Supports USB PD 3.1 (PPS) 3.3 ~ 5.9V 3A / 3.3 ~ 11V 2.25A either at Sync mode or Charge mode on each port.
- The hub will shutdown in 60 seconds at Green Energy function (the button is pressed ON) if it idles without devices connected. Manually turns on the power switch either at single unit or cascade connecting and start charging again.
- Extends up to optimum 20 / 40 USB 3.2 Gen1 devices by connecting cascade port with another unit.
- Enables Sync / Charge mode switching upon manually connecting or disconnecting host port.
- Supports over-current / short-circuit / over-temp protection on each port; Enables the specific LED to display Red blinking, meanwhile, cuts off its output power of that port.
- Supports ±15kV (air), ±8kV (contact) ESD protection on each port.
- Supports 40A (5/50ns) & Peak Pulse Power 360W (8/20 us) Surge and Transient spikes protection on each port.
- 2 DC input ports enable to power on port 1~port 10 through DC input 1, and port 11~port 20 through DC input 2. (not allowable to plug in DC input 2 individually, for 20-port unit only)
- The rear fans spec: SUNON Vapo DC Fan; Life Expectancy: 60,000 hours.
- Enables to start/cut off the fans automatically according to the temperature's setup. If the board's temperature is higher than the setting, it would start the fans automatically. On the contrary, if the board's temperature is lower from the setting, it would turn off the fans automatically as well.

Specification

Model No.		USB3-C10PD	USB3-C20PD
USB Specification		USB 3.2 Gen1 / 2.0 / 1.1 compliant	
Data Transfer Rate		1.5M / 12M / 480M / 5Gbps	
Current per Port		5V 3A / 9V 3A / 12V 2.25A / 15V 1.8A max. (27W)	
Charging Specification	Sync Mode	USB PD 3.1 (PPS) / USB Battery Charging Spec 1.2	
	Charge Mode		
Connector	Host	USB Type C Female	
	Downstream	USB Type C Female x 10	USB Type C Female x 20
	Cascade	USB Type C Female	
Power Supply		DC19V 15.75A (300W)	DC19V 15.75A (300W) x 2

Green Energy		Push Button Switch	
LED	Sync Mode	Orange Color x 10	Orange Color x 20
	Charge Mode	Charging in progress: Red Color x 10	Charging in progress: Red Color x 20
		Disconnected or Fully charged: Green Color x 10	Disconnected or Fully charged: Green Color x 20
	OCP, SCP, OTP	Red blinking x 10	Red blinking x 20
Environmental	Operating Temperature	0 ~ 40°C	
	Storage Temperature	0 ~ 60°C	
	Humidity	0-80% RH, Non-condensing	
Cooling Fan		SUNON Vapo DC Fan x 2	
Housing		Metal	
Dimension (L x W x H)		268 x 102 x 40 mm	

Cautions

1. End user may extend another unit of USB 3.2 Gen1 10 / 20-Port charging hub. (It allows sync or charging maximum up to 20 / 40 USB devices simultaneously.)
2. The specific cable for iPad, tablet isn't included in package accessory. Please check with your distributor regarding of using appropriate cable.

Package Contents

1. USB 3.2 Gen1 PD Charging Hub
2. Power supply with power cord
3. USB 3.2 Gen1 Type C male to male cable
4. Mounting brackets with screws
5. User manual

Physical Diagram

10-Port Charging hub

<Front View>

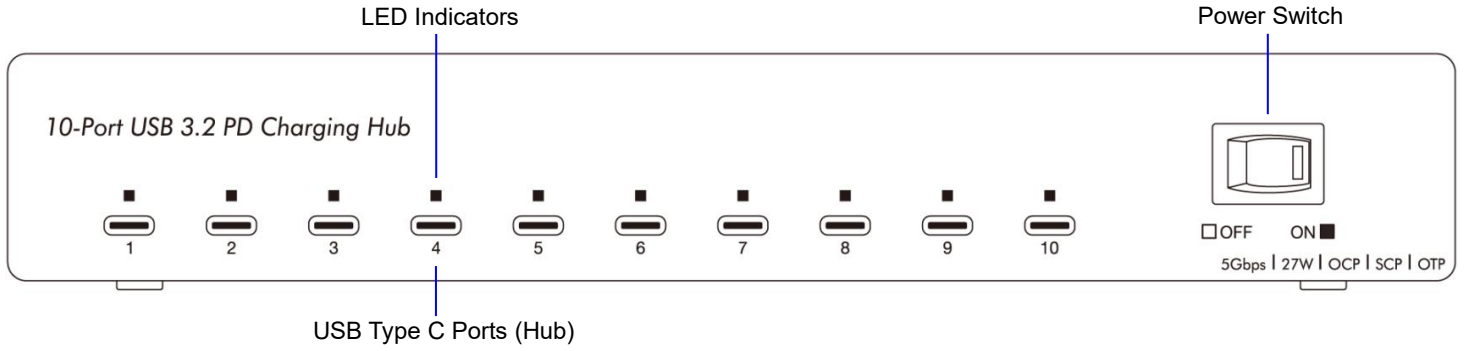

<Rear View>

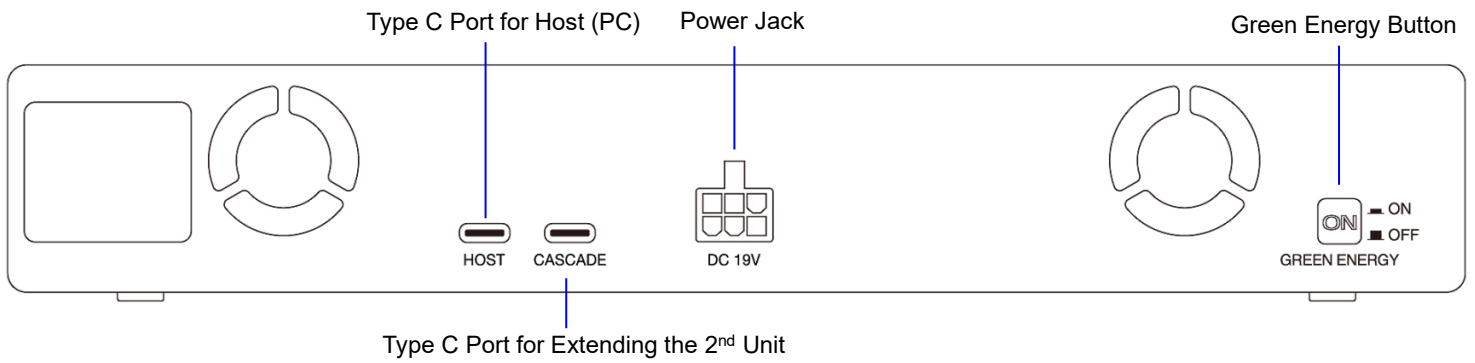

20-Port Charging hub

<Front View>

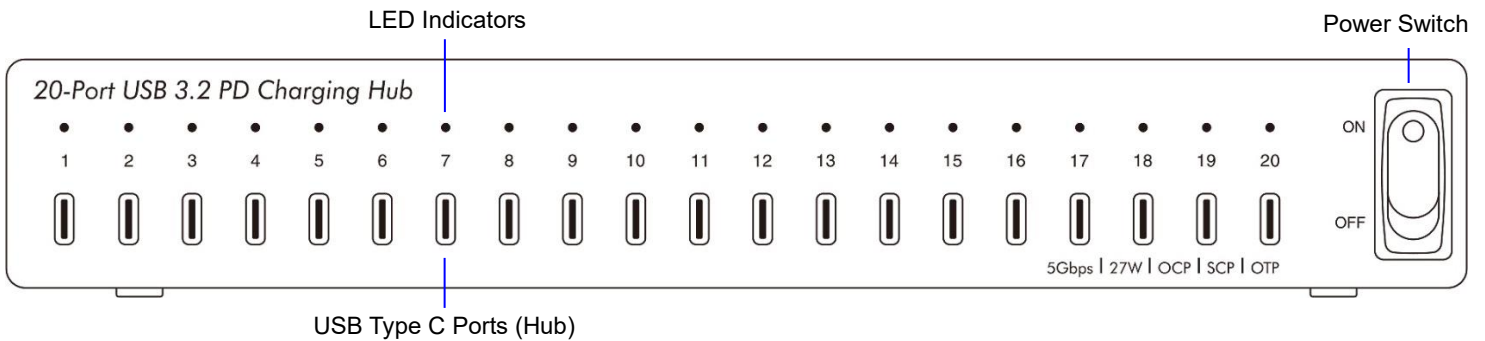

<Rear View>

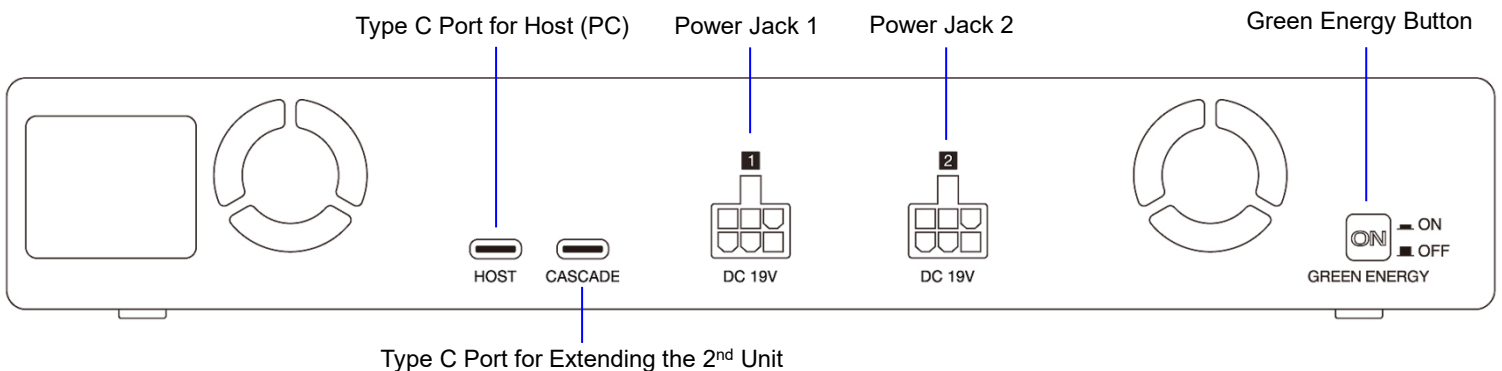

1. **USB Ports** - Allows connecting iOS, iPadOS, Android devices and MacBook Air, MacBook Pro or Chromebook etc.
 - Beware that this unit does not require a host computer connected to the hub for it to charge compatible devices.
 - This unit does not contain accessory set of cables for iPad, tablet. Please check with your distributor regarding of using appropriate cable.
2. **LED Indicators**
 - Fully charged or devices disconnected: Green LED illuminates
 - The ports of charging in progress: Red LED illuminates
 - Syncing: Orange LED illuminates
3. **Power switch**
 - User may switch power to on / off.
4. **Power jack**
 - To use with power adaptor provided.
5. **USB port for extending the 2nd unit**
 - It is available to connect with another unit for extending purpose.
6. **USB port for host (PC)**
 - It is available to connect with host computer by USB cable.
7. **Green Energy button**
 - It is available to automatically shutdown upon fully charged.

Rack Mounting

To install, attach the mounting brackets to the unit's side panels (one on each side) and secure them with the screws provided.

- (1) Use the mounting brackets and screws onto rack.

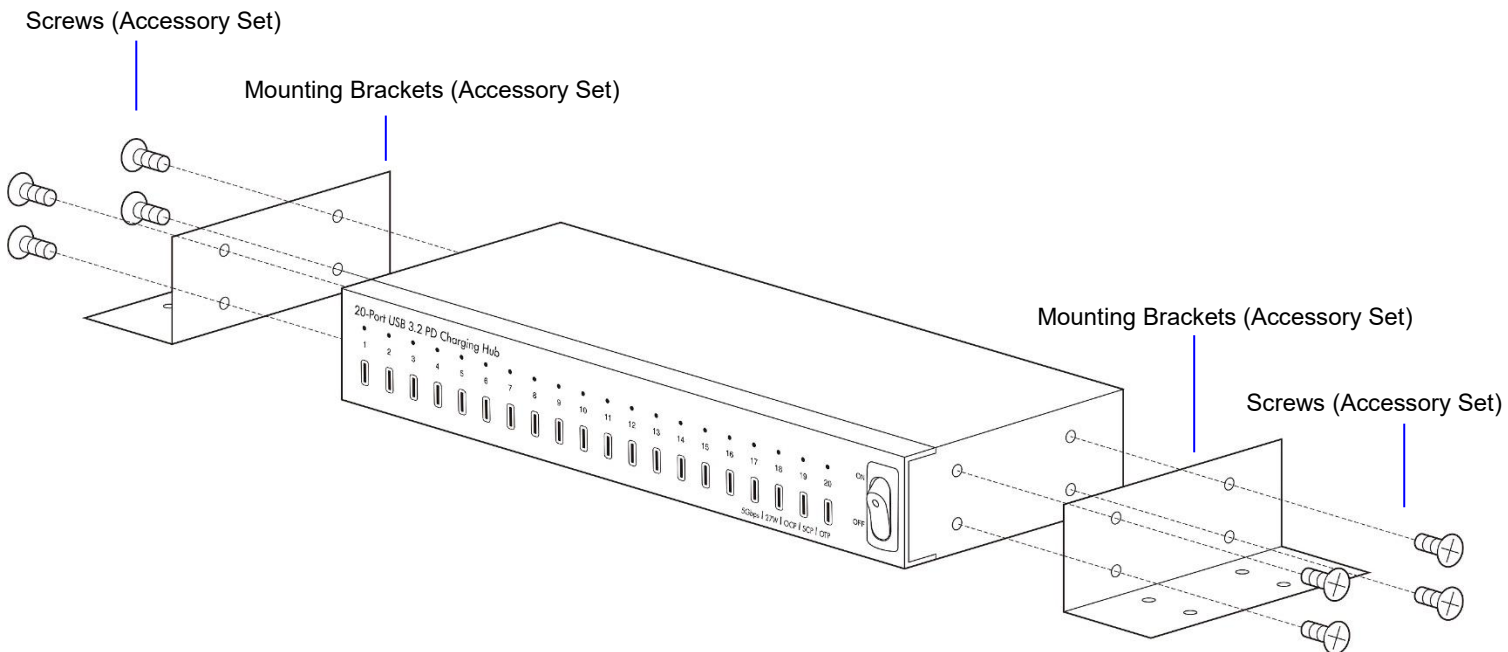

(2) User may install on the applicable cabinet, rack environments such as a cage or trolley cart.

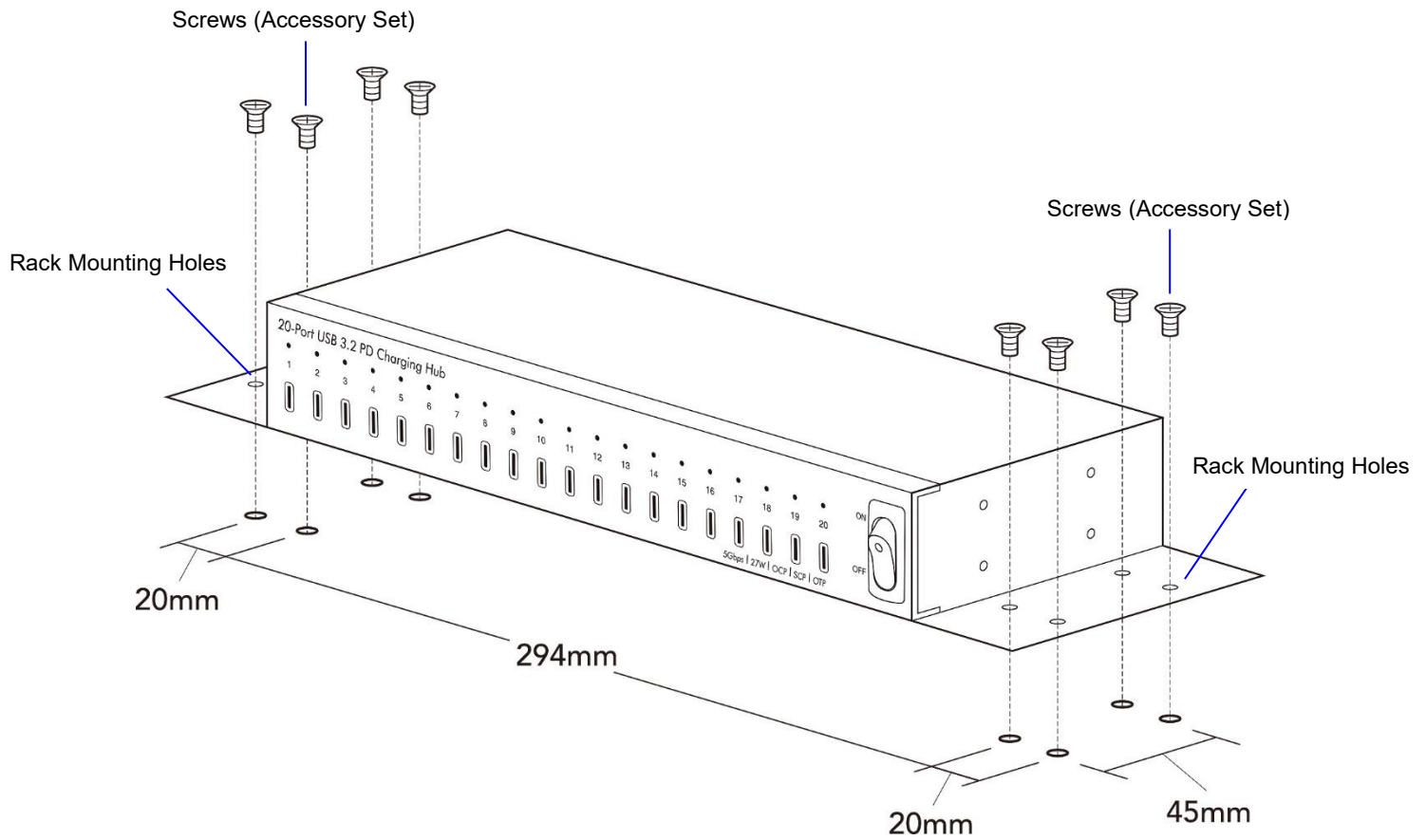

Connection

(1) To turn off the power switch.

<Front Panel>

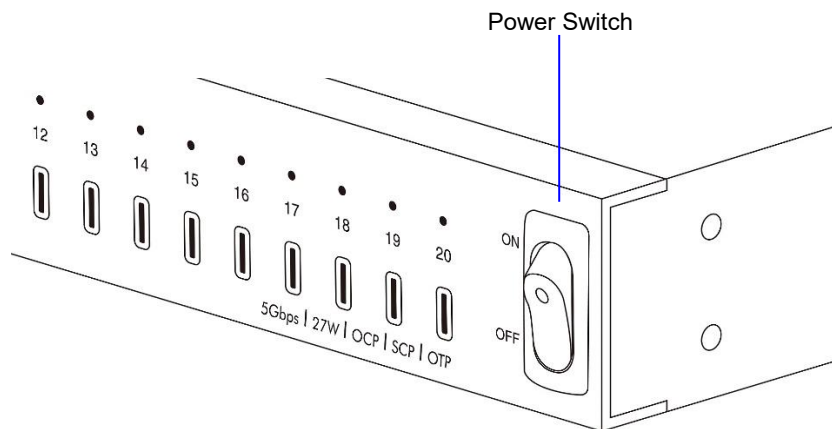

- (2) Plug the power adaptor to the unit's power jack.
- (3) Put the plug of power adaptor into the wall outlet.

<Rear Panel>

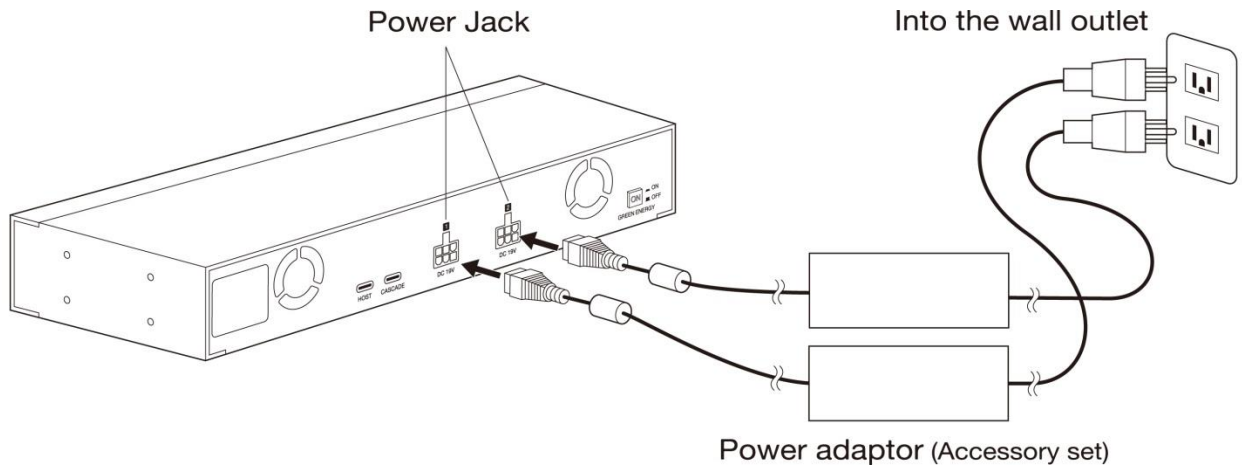

- (4) Turn on the power switch.

<Front Panel>

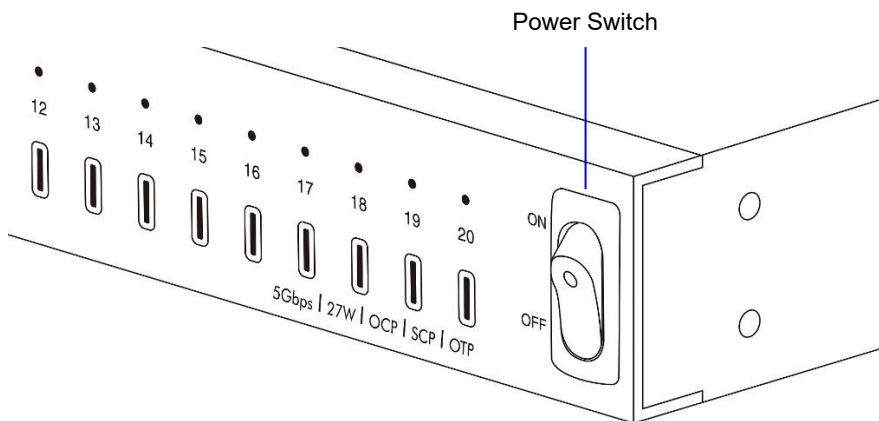

(5) Using the USB 3.2 Gen1 Type C male to male cable provided and connects the USB Type C end on the unit.

(6) Using the USB 3.2 Gen1 Type C male to male cable end and connects to your host computer.

<Rear Panel>

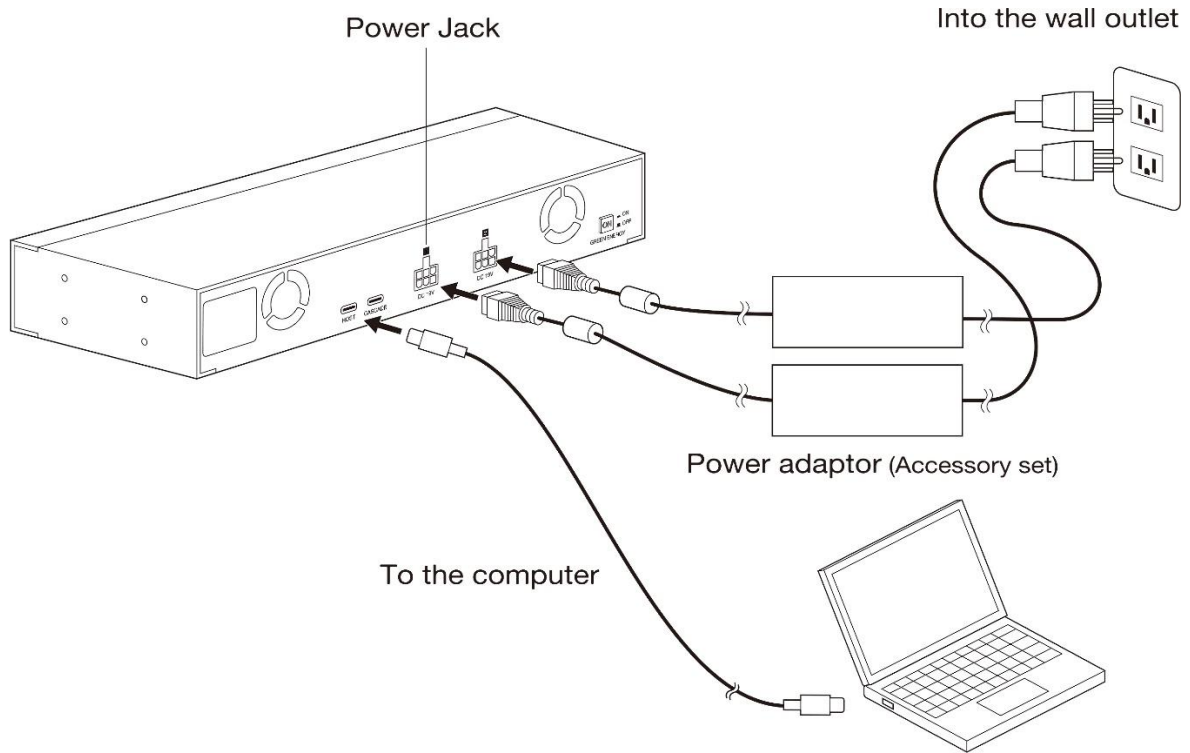

(7) To use USB cable and connects with iPad, tablet or USB Type C devices to the USB ports (Front Panel).

<Front Panel>

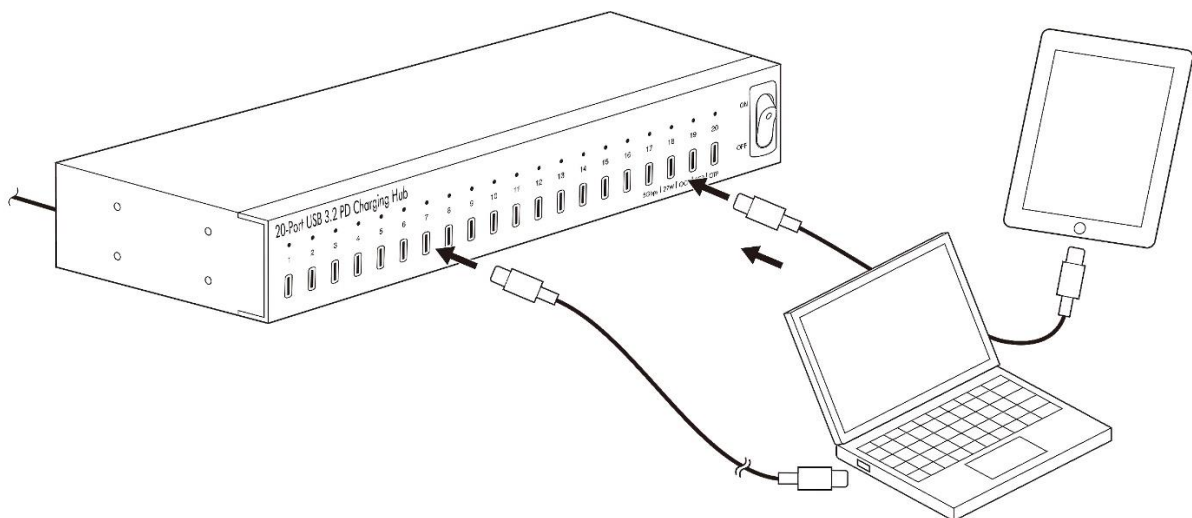

Charging & Syncing

Please follow below ways for charging or syncing USB Type C devices.

(1) Follows the step of connection with host computer, and connects host computer with the unit.

- This unit does not contain accessory set of cables for iPad, tablet. Please check with your distributor regarding of using appropriate cable.

(2) Connect your USB Type C devices to the USB Type C ports on the hub.

➤ Sync mode

- As soon as the Type C Charging hub connects to a computer, turn the power on; the Type C charging hub may charge and sync at a time either at single unit or cascade connecting.
- The Charging hub can be used with iTunes / Finder & Apple Configurator for synchronization and management of iPads and other iOS devices.
 - For Windows computers, "iTunes" is recommended to use.
 - For Mac computers, "Finder" or "Apple Configurator" is recommended to use.
 - Using different Apple IDs of devices at the same time, it is recommended to use "Apple Configurator" for synchronization and management.
 - Here is the supported operation of iTunes/Finder & Apple Configurator.
 - a. iTunes/Finder: Creating backups, updating iOS, etc.
 - b. Apple Configurator: Device settings, updating iOS, installing/uninstalling applications, etc.
- ※ For detailed information on iTunes/Finder & Apple Configurator, please refer to Apple website.

- **Charge Mode** - Allows connecting iOS, iPadOS, Android devices and MacBook Air, MacBook Pro or Chromebook etc.

- **Charge/Sync mode switching** - While the Type C Charging hub disconnects the computer, it will switch function to Charge mode. Re-connect the computer and it will switch function to Sync mode again either at single unit or cascade connecting.

- Re-start the hub on cascade connections – If the 2 hubs are cascade connecting, you must turn their power switches on for the 2 hubs. Once the 1st hub is disconnected to the computer, the 2nd hub will switch to Charge mode and work on same function.

- On the contrary; once the 1st hub is connected to the computer again, the 2nd hub will re-start and switch to Sync mode, and work on same function. (Make sure all their power switches of the 2 hubs are turned at 'ON')

(3) The Green Energy function

When charging is at Charge mode; the Type C charging hub designed with the Green Energy function (push button at the rear panel) may cut off the power when all the charging is finished.

➤ Green energy ON:

- Button's green LED illuminating.
- This function has no any effect in Sync mode.
- When all devices are fully charged in 5 seconds, the Type C charging hub will shut down automatically. You may manually turn on the power switch or re-connect to the computer and start charging again either at single unit or cascade connecting.
- If no device is connected, the charging hub will automatically shut down after 60 seconds. You can manually switch the power switch or reconnect the computer to start it. Please make sure the power switch is in the ON position.

- Green energy OFF - Button's green LED lights off. When all devices are fully charged, the hub still keeps operating; and the port LEDs keep green illuminating. Once it senses the device's battery consumed, the hub starts recharging.

Please note that the charging hub only serves as a pathway for communication between your devices and the computer. Actual management and synchronization is handled by software or apps independent of this charging hub.

(3) Plug the power adaptor to the power jack of the 2nd unit.

(4) Put the plug of power adaptor into the wall outlet.

<Rear Panel>

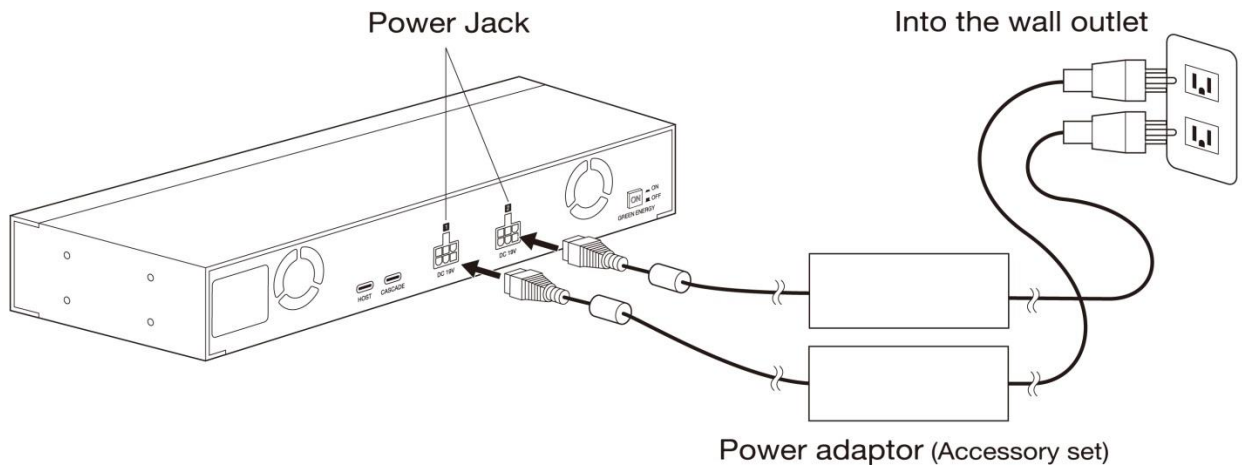

(5) Turn on the power switch of the 2nd unit.

<Front Panel>

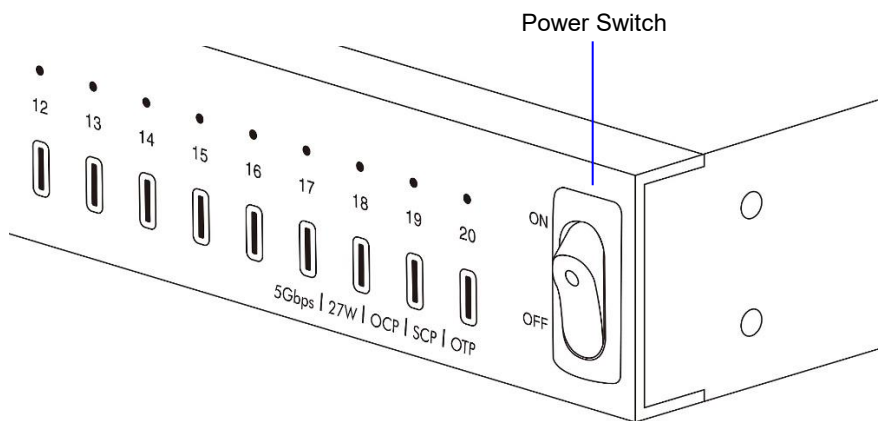

(6) Use the USB Type C cable provided and connects both USB Type C ports of the 1st and the 2nd units.

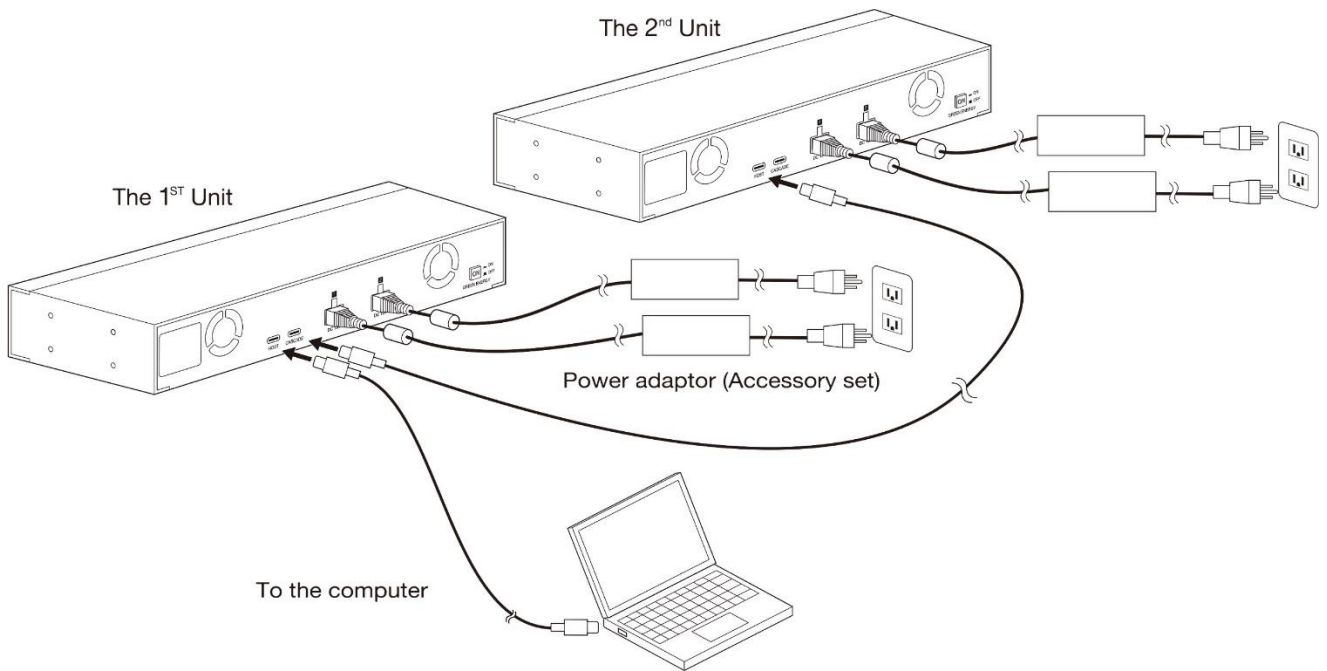

Additional info

The 10 / 20-Port Type C Charging Hub may start/cut off the fans automatically when the unit temperature goes higher/lower limits. (Not recommend putting the unit at places of high temperature such as computer facilities, boiler/steam room, glass workshop, casting work, kiln plants etc.)

- If the connection port activates over-current / short-circuit / over-temp protection, the output current of the port will be cut off. At the meantime, the Red LED will be blinking.
- If over-temp protection / over-current protection or short-circuit protection is activated, after the problem is eliminated, you can switch the power ON/OFF again or plug and unplug the Host Cable to return to the default settings

If you still cannot diagnose the problem, please call your distributor for technical support.

CE/FCC & Recycling Information

CE Certification

This equipment complies with the requirements relating to Electromagnetic Compatibility Standards EN55032 / EN55035 and the further Standards cited therein. It must be used with shielded cables only. It has been manufactured under the scope of RoHS compliance.

FCC Certification

This equipment has been tested and found to comply with the limits for a Class B digital device, pursuant to part 15 of the FCC Rules. These limits are designed to provide reasonable protection against harmful interference in a residential installation. You are cautioned that changes or modification not expressly approved by the party responsible for compliance could void your authority to operate the equipment.

This device complies with part 15 of the FCC Rules.

Operation is subject to the following two conditions:

1. This device may not cause harmful interference, and
2. This device must accept any interference received, including interference that may cause undesired operation



WEEE (Waste of Electrical and Electronic Equipment), Recycling of Electronic Products

In 2006 the European Union introduced regulations (WEEE) for the collection and recycling of all waste electrical and electronic equipment. It is no longer allowable to simply throw away electrical and electronic equipment. Instead, these products must enter the recycling process.

Each individual EU member state has implemented the WEEE regulations into national law in slightly different ways. Please follow your national law when you want to dispose of any electrical or electronic products. More details can be obtained from your national WEEE recycling agency.

