

# USB 2.0 12-Port Type C Hi-Power Charging Hub

## User's Manual



USB-2012TC

# Table of Contents

- Introduction ..... 2
  - Features..... 2
  - Specification ..... 2
  - Package Contents ..... 3
- Physical Diagram ..... 3
- Rack Mounting ..... 4
- Connection ..... 5
- Charging & Syncing..... 6
- Daisy-chain (Cascade) connection ..... 8
- Regulatory Compliance ..... 10

## Introduction

The 12-Port USB 2.0 Type C Hi-Power Charging Hub is a solution for quick charging or sync up to 12 USB Type C devices. This is a perfect tool to effectively save energy and cool down the unit's heat. Also is ideal for large capacity USB station in-house that enables charging and syncing at a time; automatically recharging once the devices connected have consumed their power with remaining 90% (approximately) after fully charged. Places such as school's classroom, businesses conference or meeting in organizations.

## Features

- Supports Downstream Facing Port (DFP).
- Compliant with USB Spec. 2.0 / USB Type C Spec 1.2 & USB Battery Charging Spec 1.2
- Enables to provide up to 5V 3A output current on each port; Supports iOS, Android devices.
- Extends up to optimum 48 USB Type C devices by connecting cascade port with another 3 units.
- Enables Sync/Charge mode switching upon manually connecting or disconnecting host port.
- Enables Green Energy function automatically shutdown the hub when all devices are fully charged at Charge mode.
- Supports Over-Current Protection & Short Circuit Protection on each port.
- For the Over Temperature Protection, if the unit's high temperature is over the setting, it would cut off all the output current immediately. At the meantime, the whole 12 ports LED would be green blinking.
- Supports  $\pm 15\text{kV}$  (air),  $\pm 8\text{kV}$  (contact) ESD protection on each port.
- Supports 40A (5/50ns) & Peak Pulse Power 45W (8/20 us) Surge and Transient spikes protection on each port.
- The rear fans spec: SUNON Vapo DC Fan; Life Expectancy: 60,000 hours
- Enables to start/cut off the fans automatically according to the temperature's setup. If the board's temperature is higher than the setting, it would start the fans automatically. On the contrary, if the board's temperature is lower from the setting, it would turn off the fans automatically as well.

## Specification

Model No.	USB-2012TC	
Current per Port	DC5V 3A	
USB Specification	USB 2.0/1.1/1.0 compliant	
Charging Specification	USB Type C Spec 1.2 & USB Battery Charging Spec 1.2	
Connector	Host	USB Type C Female
	Downstream	USB Type C Female x 12
	Cascade	USB Type C Female
Power Supply	DC12V 24A (288W)	
Green Energy	Green Energy Button	
LED	Sync mode	Orange Color x 12
	Charge mode	Charging in progress: Red Color x 12
		Disconnected or Fully charged: Green Color x 12
	Over current protection	Red blinking X12
	Short circuit protection	Red/Green Alternate blinking X12
Over temp. protection	Green blinking X12	
Environmental	Operating Temperature	0 ~ 40°C
	Storage Temperature	0 ~ 60°C
	Humidity	0-80% RH, Non-condensing
Cooling Fan	SUNON Vapo DC Fan x 2	
Housing	Metal	
Dimension (L x W x H)	268 x 102 x 40 mm	

**\*Note:** When the unit is working at sync mode, all the 12 ports LED illuminate orange all the time, no matter with Over current protection or Short circuit protection.

When it detects there are 4 ports or more deliver current over 3.6A each port, the unit would enable Over Current Protection immediately. All the 12 ports LED activate Red blinking and shutdown the unit power.

## Package Contents

- USB 2.0 12-Port Type C Hi-Power Charging Hub
- Power supply with power cord
- USB 2.0 Type C male to male cable
- Mounting brackets with screws
- User manual

## Physical Diagram

<Front View>

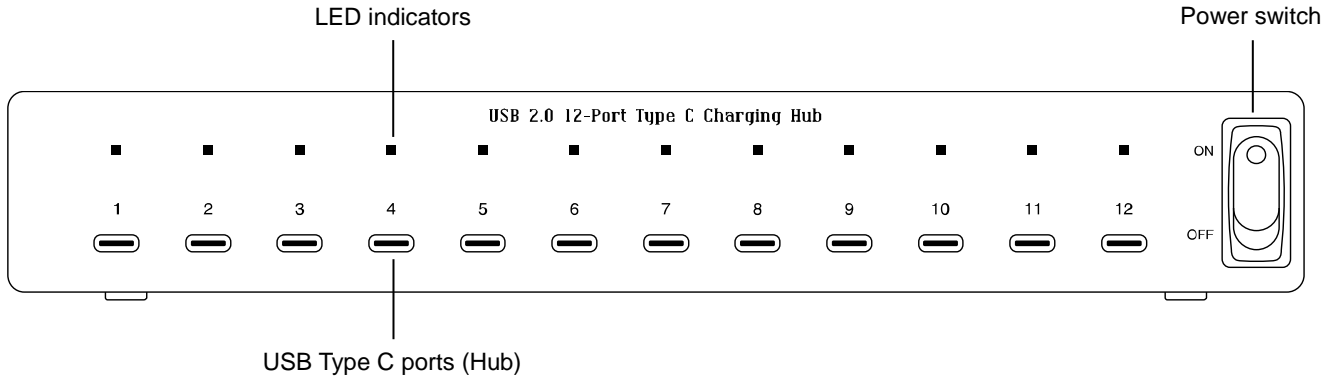

<Rear View>

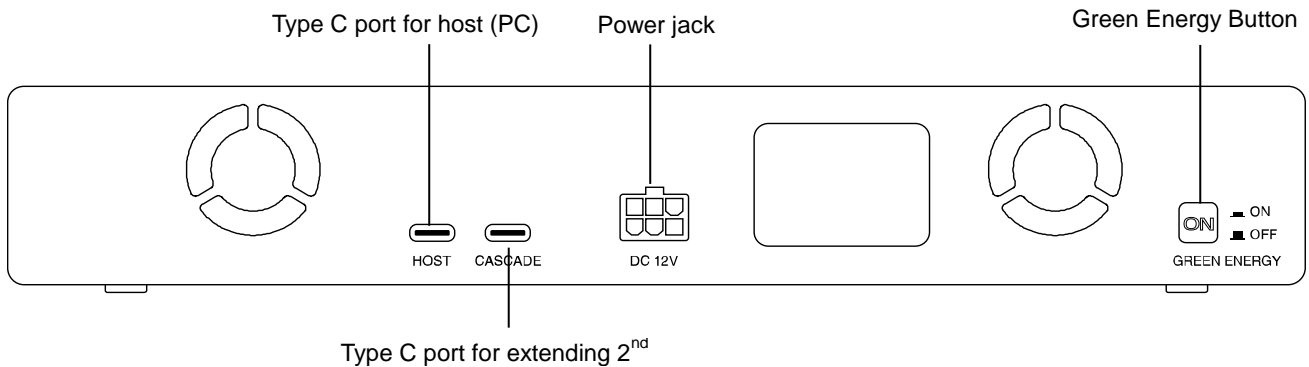

1. USB Type C Ports (Hub) - Allows connecting iPad, tablet or USB Type C mobile devices
  - Beware that this unit does not require a host computer connected to the hub for it to charge compatible devices.
  - This unit does not contain accessory set of cables for iPad, tablet. Please check with your distributor regarding of using appropriate cable.
2. LED Indicators
  - LED illuminates Green: Fully charged or devices disconnected
  - LED illuminates Red: The port of Charging in progress
  - LED illuminates Orange: The port of Syncing
  - LED displays Red blinking: the unit is functioning Over Current Protection
  - LED displays Red/Green Alternate blinking: the unit is functioning Short Circuit Protection
  - LED displays Green blinking: the unit is functioning Over temperature Protection
3. Power switch
  - User may switch power to on / off.
4. Power jack
  - To use with power adaptor provided.

5. USB Type C port for extending 2<sup>nd</sup> unit
  - It is available to connect with another unit for extending purpose.
6. USB Type C port for host (PC)
  - It is available to connect with host computer by USB Type C cable.
7. Green Energy button
  - It is available to automatically shutdown upon fully charged.

## Rack Mounting

To install, attach the mounting brackets to the unit's side panels (one on each side) and secure them with the screws provided.

- (1) Use the mounting brackets and screws onto rack.

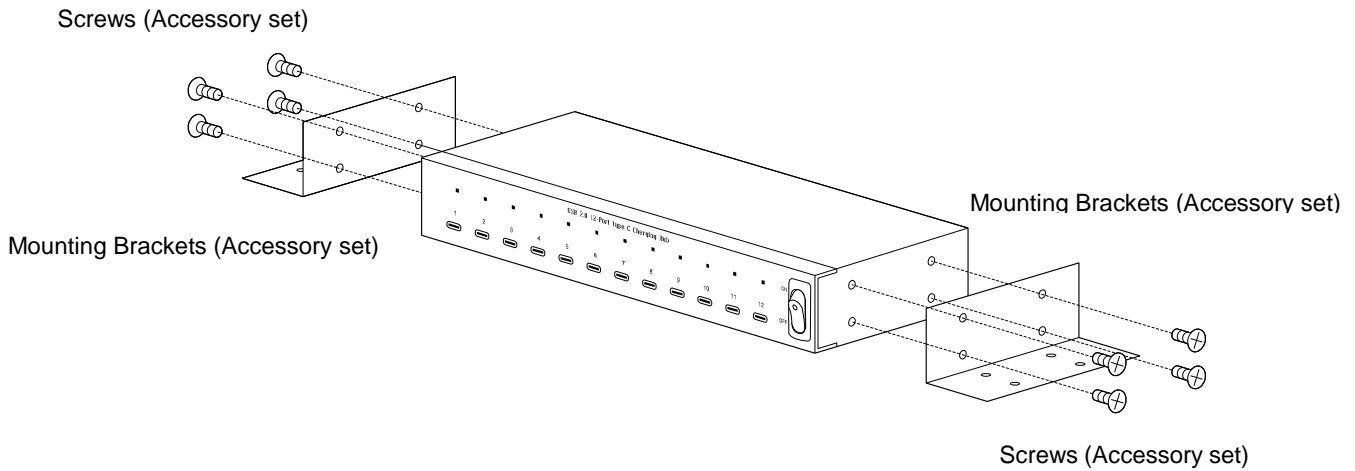

- (2) User may install on the applicable cabinet, rack environments such as a cage or trolley cart.

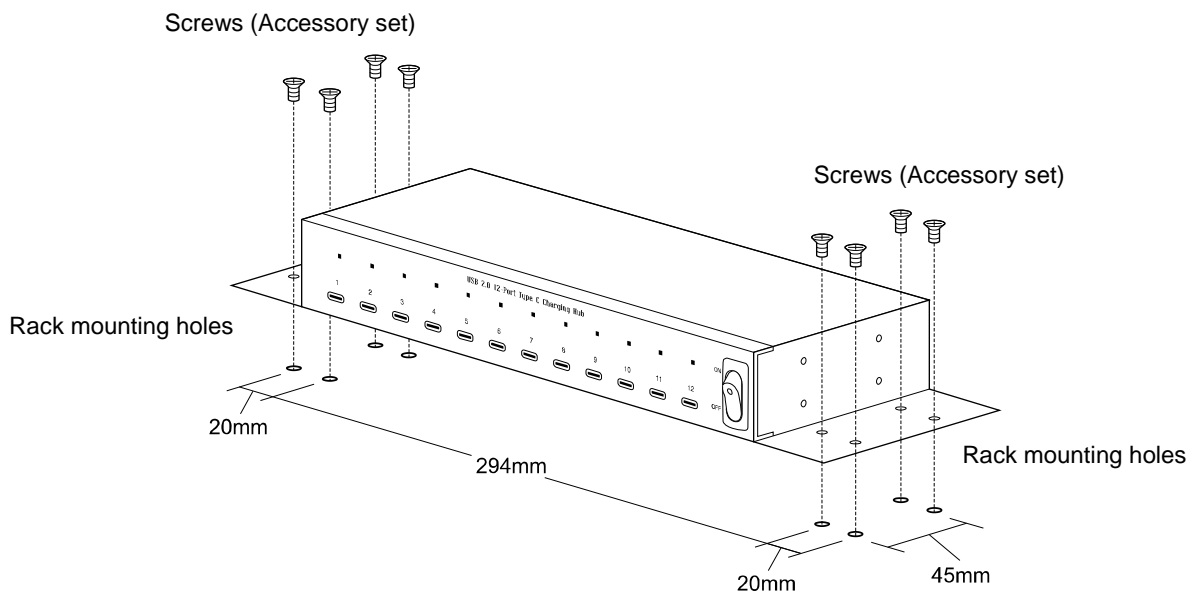

## Connection

- (1) To turn off the power switch.

<Front Panel>

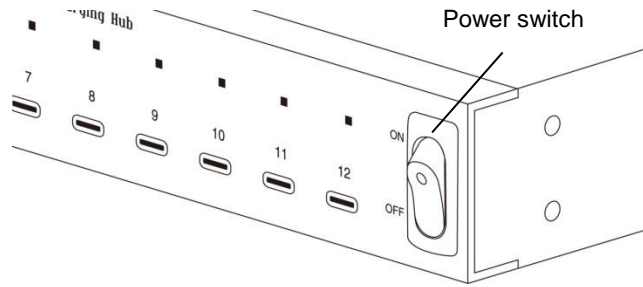

- (2) Plug the power adaptor to the unit's power jack.

- (3) Put the plug of power adaptor into the wall outlet.

<Rear Panel>

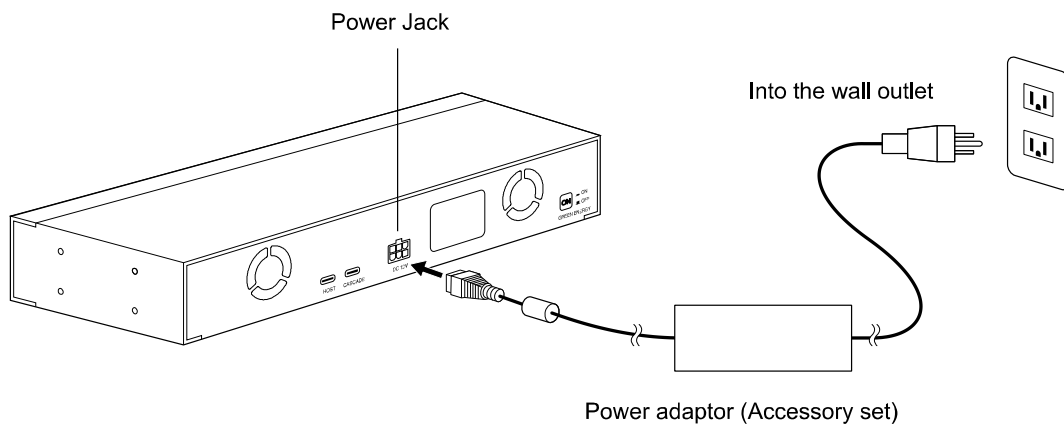

- (4) Turn on the power switch.

<Front Panel>

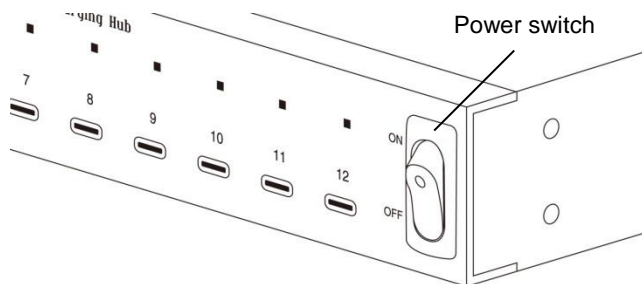

- (5) Using the USB Type C cable provided and connects one end on the unit.

- (6) Using the other end and connects to your host computer.

- (7) Connects host computer with the unit.

## <Rear Panel>

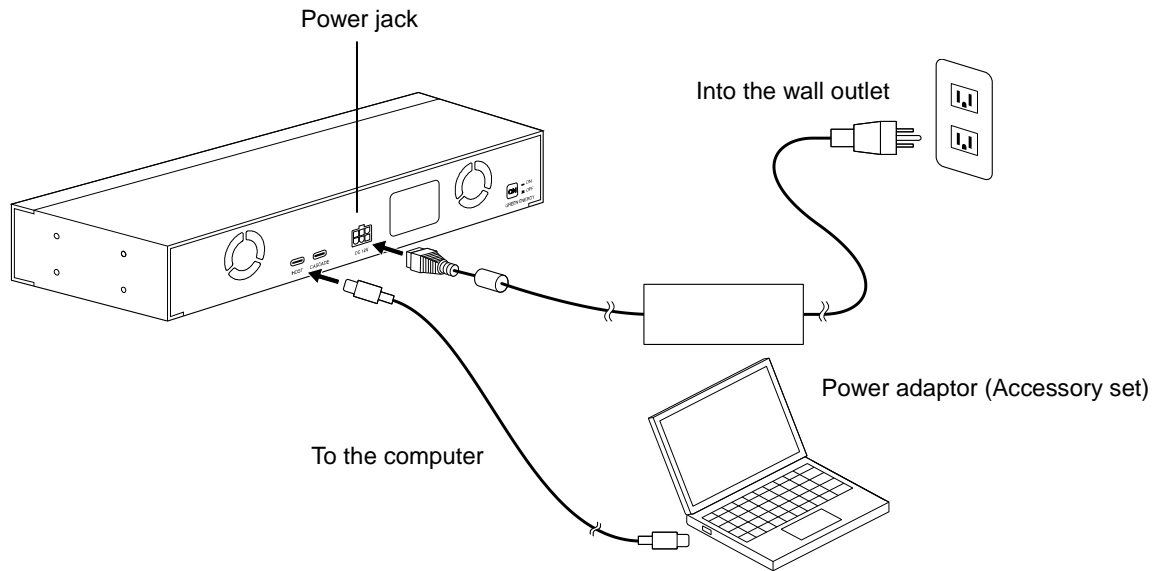

(8) To use USB Type C cable and connects with tablet or USB Type C devices to the Type C ports (Front Panel).

## <Front Panel>

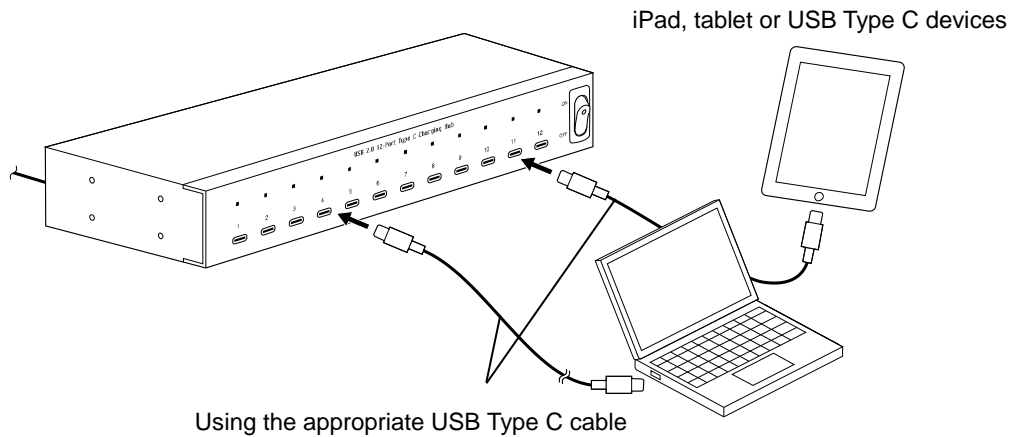

## Charging & Syncing:

Please follow below ways for charging or syncing USB Type C devices.

- (1) Follows the step of connection with host computer, and connects host computer with the unit.
  - This unit does not contain accessory set of cables for iPad, tablet. Please check with your distributor regarding of using appropriate cable.
- (2) Connect your USB Type C devices to the USB Type C ports on the hub.
  - Sync mode - As soon as the Type C Charging hub connects to a computer, turn the power on; the Type C charging hub may charge and sync at a time either at single unit or cascade connecting.
  - Charge/Sync mode switching –
    - a. While the Type C Charging hub disconnects the computer, it will switch function to Charge mode. Re-connect the computer and it will switch function to Sync mode again either at single unit or cascade connecting.
    - b. The hub will shutdown in 60 seconds at Green Energy function (the Green Energy button is pressed ON) if it idles without devices connected. You may manually turn on the power switch either at single unit or cascade connecting and start charging again.
    - c. Or you may re-connect to the computer to restart the charging hub and it will switch function to Sync (CDP mode) again either at single unit or cascade connecting. (Make sure their power switches of the 2~4 hubs are turned at 'ON')
  - If all devices are fully charged at Charge mode, the Type C charging hub will shutdown automatically. You may manually turn on the power switch or re-connect to the computer and start charging again.

- Re-start the hub on cascade connections – If the 2~4 hubs are cascade connecting, you must turn their power switches on for the 2~4 hubs. Once the 1<sup>st</sup> hub is disconnected to the computer, the 2~4 hubs will switch to Charge mode and work on same function.  
On the contrary; once the 1<sup>st</sup> hub is connected to the computer again, the 2~4 hubs will re-start and switch to Sync mode, and work on same function. (Make sure all their power switches of the 2~4 hubs are turned at 'ON')

### (3) The Green Energy function

When charging is at Charge mode; the Type C charging hub designed with the Green Energy function (push button at the rear panel) may cut off the power when all the charging is finished.

- Green energy ON: Button's green LED illuminating. When all devices are fully charged, the Type C charging hub will shutdown automatically. You may manually turn on the power switch or re-connect to the computer and start charging again either at single unit or cascade connecting.
- Green energy OFF: Button's green LED lights off. When all devices are fully charged, the hub still keeps operating; and the port LEDs keep green illuminating. Once it senses the device's battery consumed, the hub starts recharging.

#### **Note 1.:**

When the unit is working at sync mode, all the 12 ports LED illuminate orange all the time, no matter with Over current protection or Short circuit protection.

When it detects there are 4 ports or more deliver current over 3.6A each port, the unit would enable Over Current Protection immediately. All the 12 ports LED activate Red blinking and shutdown the unit power.

#### **Note 2.:**

The Charging hub can be used with iTunes & Apple Configurator for synchronization and management of iPads and other iOS devices. For this and any other application (on Windows, Linux, etc.) the charging hub acts as a USB hub. While these instructions are specific to iPads, virtually the same steps can be used for iPhones and iPod Touch devices.

**Please note that the charging hub only serves as a pathway for communication between your devices and the computer. Actual management and synchronization is handled by software or apps independent of this charging hub.**

### **[ For host computer configuring iTunes ]**

- Please create a library folder on host computer for synchronizing and transfers data to iPad.
- Recommends automatic updates in your iTunes preferences (to avoid interference with automatic syncing). Please check for updates manually to keep your software up to date.

### **[ For iPad, tablet configuring ]**

- Ensure each iPad, tablet has been charged completely at first if the objective iPad, tablet is new goods.
- Please use the unit to synchronize iPad, tablet one after another, and configure at same way. (Login name, ID, the data you want to synchronize etc.)
- The user may adjust the brightness of screen when you are using the unit to synchronize iPad.
- When the user may be requested by iTunes to configure manually, you will have to copy the configuration manually for each iPad.

### **[ For host computer connection & sync ]**

- Connect iPad, tablet to the USB Type C ports of front panel if each iPad, tablet is configured completely.
- This unit does not contain accessory set of cables for iPad, tablet. It is especially important to use appropriate cables (USB Type C to device-specific connector) provided by the device manufacturer.
- Get started synchronizing automatically once you connect the unit.
- It may take a little while for this unit to recognize and sync. Please do not stop by the way once the unit starts synchronizing.

### **[ For iOS update ]**

- User may not perform the iPad update when iPad is connected. You must update iOS on iPad one after another.



## Daisy-chain (Cascade) connection

The 12-Port Type C charging hub can extend another unit for Daisy-chain (Cascade) connection, the 2<sup>nd</sup> unit can sync simultaneously as well.

- Maximum 4 units can be connected. (It allows connecting or charging maximum up to 48 USB Type C devices simultaneously.)
- If user connects with two units, the 2<sup>nd</sup> unit may not be detected by some computers which have built in USB 3.0 hub.

(1) Follows the step of connection with host computer, and connects host computer with the 1<sup>st</sup> unit.

<Rear Panel>

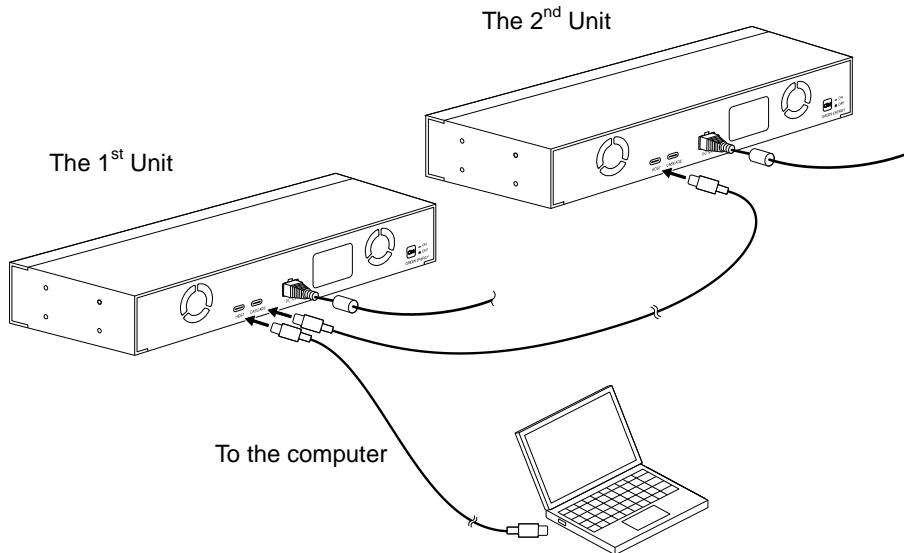

(2) Turn off the power switch of the 2<sup>nd</sup> unit.

<Front panel>

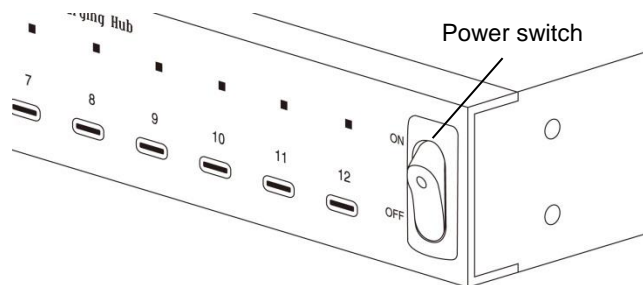

(3) Plug the power adaptor to the power jack of the 2<sup>nd</sup> unit.

(4) Put the plug of power adaptor into the wall outlet.

<Rear Panel>

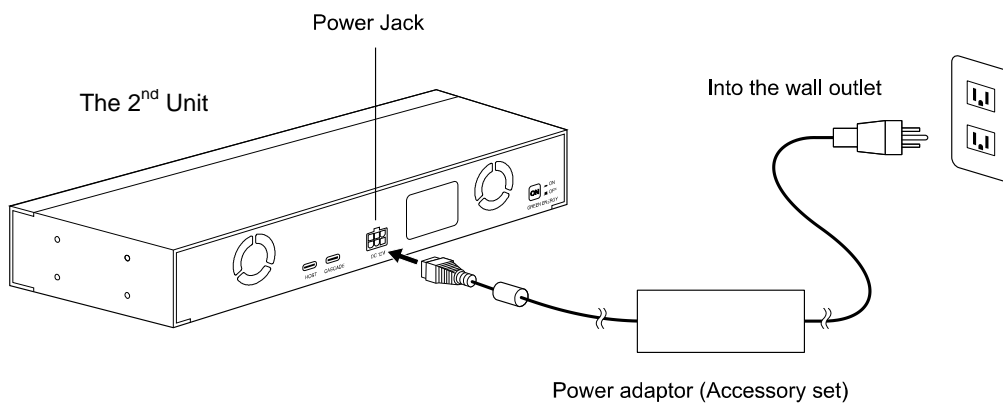

(5) Turn on the power switch of the 2<sup>nd</sup> unit.

<Front Panel>

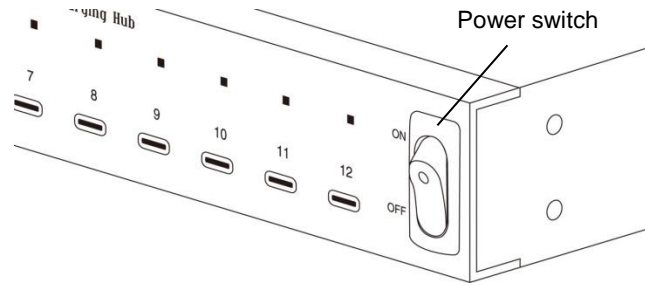

(6) Use the USB Type C cable provided and connects both USB Type C ports of the 1<sup>st</sup> and 2<sup>nd</sup> units.

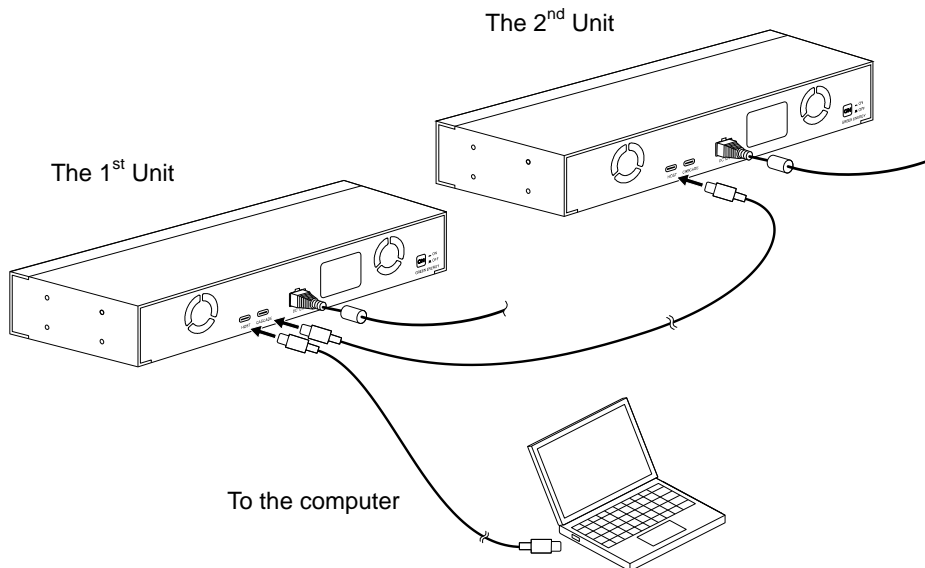

### Additional info:

The 12-Port Type C Charging Hub may start/cut off the fans automatically when the unit temperature goes higher/lower limits. (Not recommend putting the unit at places of high temperature such as computer facilities, boiler/steam room, glass workshop, casting work, kiln plants etc.)

For the High-temp protection, if the unit's heat is over the setting, it would cut off all of the output current immediately. At the meantime, the whole LEDs of the 12 ports would be green blinking.

If you still cannot diagnose the problem, please call your distributor for technical support.

## Regulatory Compliance

### Disclaimer

Information in this document is subject to change without notice. The manufacturer does not make any representations or warranties (implied or otherwise) regarding the accuracy and completeness of this document and shall in no event be liable for any loss of profit or any other commercial damage, including but not limited to special, incidental, consequential, or other damages.

No part of this document may be reproduced or transmitted in any form by any means, electronic or mechanical, including photocopying, recording or information recording and retrieval systems without the express written permission of the manufacturer.

All brand names and product names used in this document are trademarks, or registered trademarks of their respective holders.

### CE Certification

This equipment complies with the requirements relating to electromagnetic compatibility.

It has been manufactured under the scope of RoHS compliance.

### FCC Compliance Statement

This equipment generates and uses radio frequency and may cause interference to radio and television reception if not installed and used properly. This equipment has been tested and found to comply with the limits of a Class B digital device, pursuant to part 15 of the FCC Rules. These limits are designed to provide reasonable protection against harmful interference in a residential installation.

You are cautioned that changes or modification not expressly approved by the party responsible for compliance could void your authority to operate the equipment.

This device complies with part 15 of the FCC Rules. Operation is subject to the following two conditions:

- (1) This device may not cause harmful interference, and
- (2) This device must accept any interference received, including interference that may cause undesired operation



### WEEE (Waste of Electrical and Electronic Equipment), Recycling of Electronic Products

In 2006 the European Union introduced regulations (WEEE) for the collection and recycling of all waste electrical and electronic equipment. It is no longer allowable to simply throw away electrical and electronic equipment. Instead, these products must enter the recycling process.

Each individual EU member state has implemented the WEEE regulations into national law in slightly different ways. Please follow your national law when you want to dispose of any electrical or electronic products. More details can be obtained from your national WEEE recycling agency.